

IDENTIFICATION OF MACHINES

Each UNION SPECIAL LEWIS machine carries a style number, which in this class of machines, is stamped in the style plate on the left side of the arm.

The serial number of each machine is stamped in the right side of the cylinder toward the back.

APPLICATION OF CATALOG

This catalog is a supplement to Catalog No. 194-4 and should be used in conjunction therewith. Only those parts which are used on Style 200-28, but not on Style 200-1 are illustrated and listed at the back of this book. The parts are identified by a reference number and this reference number is then used to obtain the part number, description and amount required. Any part that is a component of another part is illustrated on the picture plate by having the reference number or numbers inside a bracket or box. On the copy page a component part is indicated by indenting its description under the description of the assembly or base part. Always use the part number in the second column, never use the reference number in the first column when ordering repair parts.

The catalog applies specifically to the Standard Style machine as listed herein. It can also be applied with discretion to other Styles of machines in this class. References to direction, such as right, left, front, back, etc., are given from the operator's position while seated at the machine. Operating direction of the pulley is away from the operator.

STYLE OF MACHINE

200-28 High Production, Single Needle, Single Thread Machine for Stitching Removable Tacks. Sews eight stitches right to left for stitching a two hole "Tack" with a 1/8 inch protruding tail permitting easy removal of "Tack". Equipped with thread wiper which pulls the severed thread tail free of the sewn tack, after the sewing cycle. Equipped to sew up to 1/4 inch wide "Tack". Type 29S-100/040 needle. Maximum recommended speed 1500 R. P. M.

OILING

These machines should be oiled twice daily, before the morning and afternoon starts. Use a good grade of straight mineral oil of a Saybolt viscosity of 90 to 125 seconds at 100° Fahrenheit.

Most of the oiling places on the machines are readily identifiable because of the fact they are painted red. However, reference to the oiling diagram Fig. 11, will be beneficial.

Please note that it will be necessary to remove arm cover and side cover and to open the hinged base covers and tilt machine on its side to reach some of the oiling places.

Also note that there is a label on the pulley which reads "Grease Here". A tube of grease is furnished with the machine and periodically the plug screw in the pulley should be removed, the grease level checked and replenished if required. The greasing place is indicated by the letter "A" in the diagram. All other places shown are oiled.

Tubes of grease may be ordered under part No. 28604 P.

ADJUSTING THREAD WIPER (Continued)

14) must swing freely towards the left until it strikes the under surface of the arm head casting. The forward end of the thread wiper drive lever (D, Fig. 13) should protrude through the cam opening of the wiper arm hook (E) at least 1/32 inch, but not into the path of, or strike the needle bar.

With the machine in "SEWING POSITION" without material under clamp, the wiper hook should be locked in position by the wiper drive lever being engaged in the locking portion of the cam slot, but the lever should have a minimum of 1/32 inch clearance from the bottom of the slot.

By co-ordinating adjustments of the wiper drive lever in the cam of the wiper arm hook and wiper drive lever bracket, the wiper arm hook shall have developed enough inertia at stop motion, after the sewing cycle, to pull the severed thread tail free of the sewn tack.



From the library of: Diamond Needle Corp

ADJUSTING THREAD WIPER (Continued)

With the machine in "STOP POSITION", there should be at least 1/8 inch clearance between the top of the thread wiper lever bracket (C) and the wiper cam hook (A). The wiper cam hook (A) should be approximately 1/16 inch to the right of the centerline of the needle (14). The wiper cam hook (A, Fig. 13) should be approximately 1/32 inch from the centerline of the needle (14) and the wiper cam hook (E) at least 1/32 inch, but not more than 1/16 inch, from the centerline of the needle (14). The wiper cam hook (E) should be approximately 1/16 inch from the centerline of the needle (14) and the wiper cam hook (E) at least 1/32 inch, but not more than 1/16 inch, from the centerline of the needle (14).

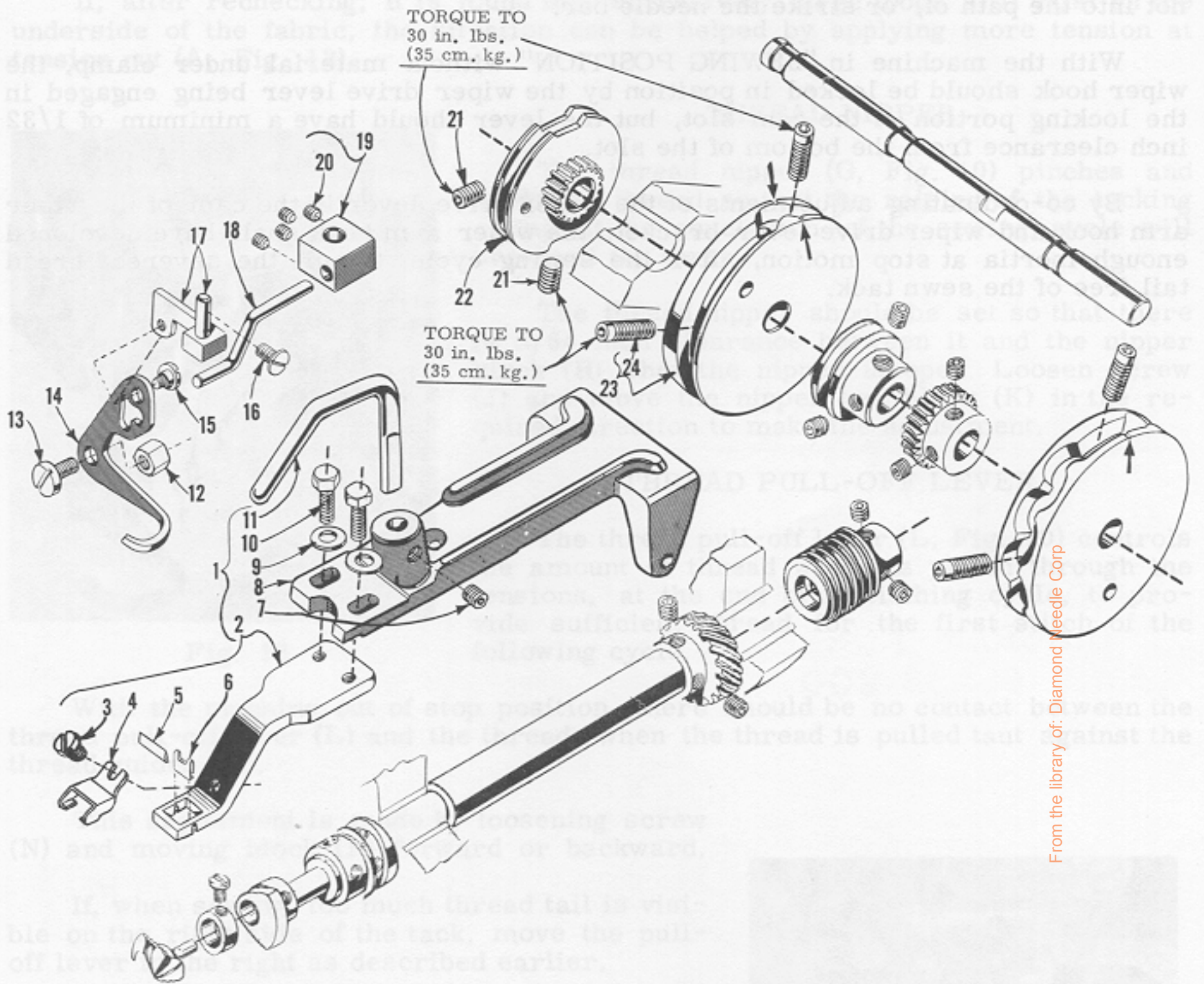

From the library of: Diamond Needle Corp

ADJUSTING THREAD WIPER

The thread wiper mounting bracket (A, Fig. 13) should be adjusted so that the wiper cam hook (A) is approximately 1/16 inch from the centerline of the needle (14) and the wiper cam hook (E) at least 1/32 inch, but not more than 1/16 inch, from the centerline of the needle (14).

With the machine in "STOP POSITION", there should be at least 1/8 inch clearance between the top of the thread wiper lever bracket (C) and the wiper cam hook (A). The wiper cam hook (A) should be approximately 1/16 inch to the right of the centerline of the needle (14). The wiper cam hook (A, Fig. 13) should be approximately 1/32 inch from the centerline of the needle (14) and the wiper cam hook (E) at least 1/32 inch, but not more than 1/16 inch, from the centerline of the needle (14).

Fig. 14

The parts illustrated on the preceding page and described below represent the parts that are used on Style 200-28, but not used on Style 200-1.

Those parts shown in phantom views and bearing no reference numbers are common to Styles 200-1 and 200-28.

Use Catalog No. 194-4 (Style 200-1) for all parts not illustrated or described in this catalog.

Reference numbers that are inside a bracket on the picture plate and have indented descriptions indicate they are component parts of a complete part or assembly.

<u>Ref. No.</u>	<u>Part No.</u>	<u>Description</u>	<u>Amt. Req.</u>
1	430-91	Tacking Clamp Assembly -----	1
2	30-92	Tacking Clamp-----	1
3	22704	Screw, for knife holding clamp -----	1
4	99-356	Knife Holding Clamp-----	1
5	119-87	Knife -----	1
6	8-140	Knife Guard -----	1
7	18-1087	Set Screw -----	1
8	99-270	Tacking Clamp Holder -----	1
9	40-38	Washer -----	2
10	18-873	Screw-----	2
11	71-112	Tacking Clamp Lifting Rod-----	1
12	HA18 A	Nut, for thread wiper arm hook-----	1
13	22548	Screw, for thread wiper arm hook -----	1
14	131-28	Thread Wiper Arm Hook -----	1
15	1776 L	Screw, for thread wiper arm hook -----	1
16	18-330	Screw, for thread wiper mounting bracket -----	1
17	50-298	Thread Wiper Mounting Bracket -----	1
18	45-484	Thread Wiper Drive Lever -----	1
19	50-299	Thread Wiper Drive Lever Bracket -----	1
20	22894 P	Set Screw -----	4
21	18-730	Set Screw, for cam and gear assembly -----	2
22	434-42-1	Cam and Gear Assembly -----	1
23	34-100	Cam, left side, for vibrating tacking plate lengthwise --	1
24	18-984	Set Screw -----	2

From the library of: Diamond Needle Corp

NEEDLES

Use only genuine UNION SPECIAL LEWIS needles. They are stamped with the word "LEWIS" on the shank.

Unless instructions to the contrary are received, machine Style 200-28 will be sewed off and shipped with needle Type 29S-100/040. This needle is a short needle, with a sharp point and has a .040 inch (1.02 mm) diameter blade.

Selection of the proper needle size is determined by the size of thread and the weight of material.

To have needle orders promptly and accurately filled, an empty container, a sample needle, or the type number should be forwarded. A complete order would read: "100 Needles, Type 29S-100/040".

CHANGING NEEDLES

When changing the needle, make sure that it is inserted in the needle bar as far as it will go, with the long groove to the front and the spot or scarf to the rear and tighten set screw securely.

A cross hole drilled in the needle bar can also be used to determine if the needle has been inserted as far as it will go.

Immediately discard any needle which may have a hooked or blunt point.

THREADING

To thread machine, put in stop position and thread in accordance with threading diagram Fig. 11.

ADJUSTING

CAUTION! Do not run the machine under power during the following adjusting operations until ready to sew.

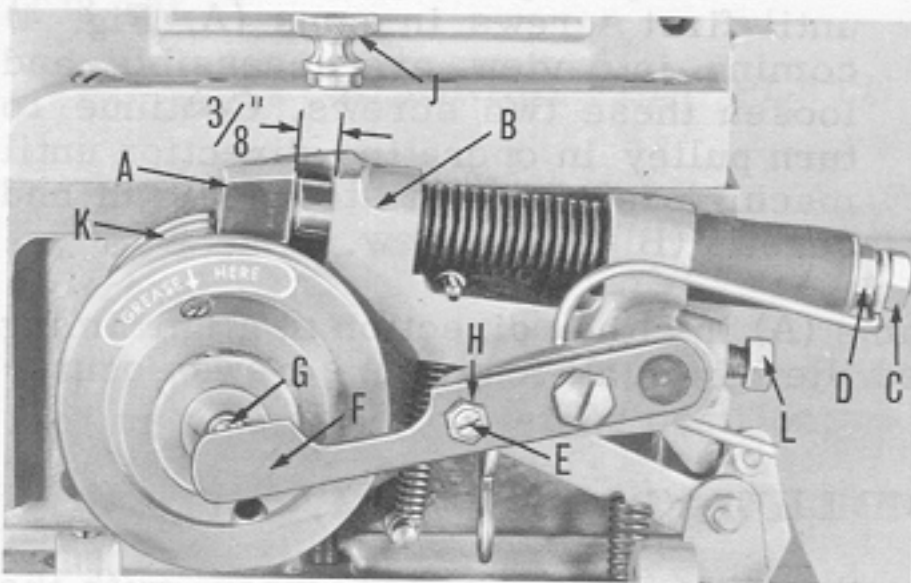

Fig. 1

operated, depress the operating treadle and turn the pulley and stop motion disc in operating direction.

Style 200-28 machines are equipped with a cycling mechanism, which, with one pressure on the operating treadle, produces 8 stitches and automatically stops.

In the following instructions, reference is made to "the machine in stop position".

This position is that which is shown in Fig. 1 with the stop motion disc and pawl (K) against the plunger (A).

To release the machine from stop position so that it may be manually

ADJUSTING CLUTCH

With the machine in stop position, the stop motion plunger (A, Fig. 1) should be set so that there is $\frac{3}{8}$ inch clearance between the bottom of the plunger and the plunger lever bracket (B). Loosen the back lock nut (C) and adjust the front nut (D) to obtain this setting. Lock the back nut. Adjust screw (E) in cam lever (F) so that there is $\frac{1}{32}$ inch clearance between ball (G) and the thin section of lever (F) when the pulley is pressed in towards machine. Lock screw with nut (H). Make sure that set screw (L) is securely tightened.

ADJUSTING STOP MOTION

With the machine in stop position, loosen the two socket head set screws (A, Fig. 2) in stop motion cam (B) and rotate cam to secure $\frac{1}{32}$ inch clearance between roller (C) and front of slot in cam.

Depress the treadle to take machine out of stop position and rotate pulley two complete revolutions in operating direction. Release treadle and measure distance between plunger (A, Fig. 3) and highest point on disc (B). The distance should be $\frac{3}{32}$ inch.

This adjustment is made by loosening clamp screw (D, Fig. 2) in stop motion trip lever and moving lever up or down to secure the $\frac{3}{32}$ inch clearance. Should it be necessary to move lever down, depress the treadle while making adjustment.

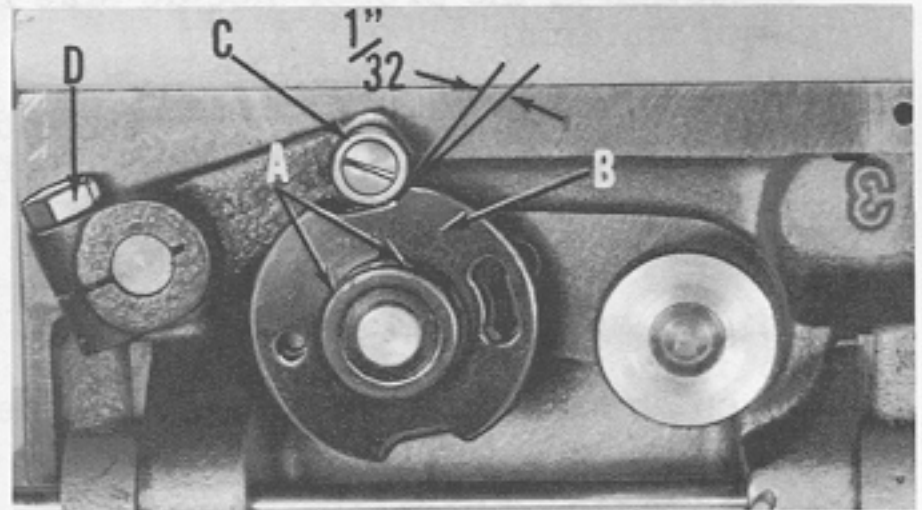

Fig. 2

TIMING CAMS

Depress treadle to take machine out of stop position and rotate pulley two complete revolutions in operating direction. Loosen knurled screw (J, Fig. 1) and lay machine on its side.

Turn pulley in operating direction until first screws in cams (A, Fig. 4) coming into view are accessible and loosen these two screws. Continue to turn pulley in operating direction until machine is again in stop position and screws (B) are in view.

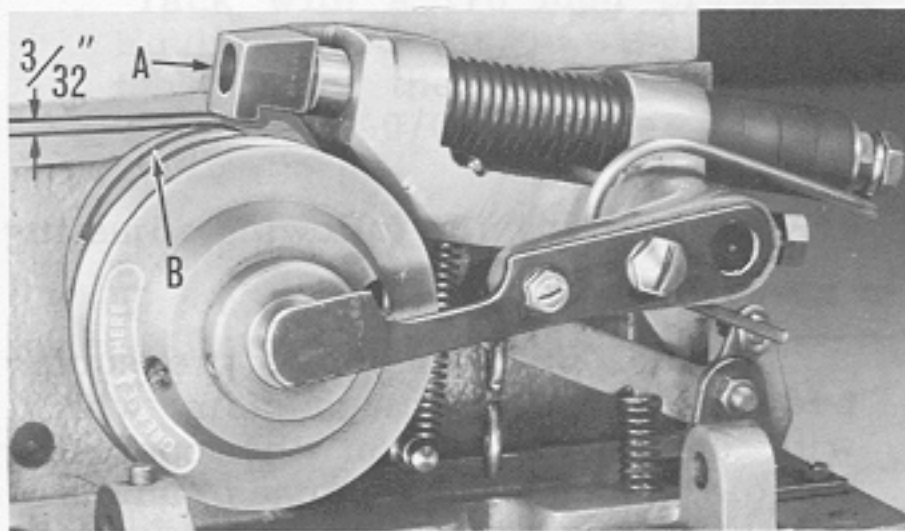

Fig. 3

Loosen the two screws (B) and turn cams (A) in either direction to align timing lines (C) on cams with timing pins (D) in bed. Retighten all four cam screws securely.

ADJUSTING CLAMP LIFTING LINK

The tacking clamp lifting link (E, Fig. 4) is in proper position, when, with the machine in stop position, the lip on the fork lever (F) is engaged in the slot of the link.

Forward and backward adjustment of the link is accomplished by loosening clamp screw (G) in lever (H) and moving lever on shaft.

ADJUSTING CLAMP LIFTING LINK (Continued)

Adjustment of the fork lever (F) is made by loosening screws in collars (J) and moving fork lever on shaft.

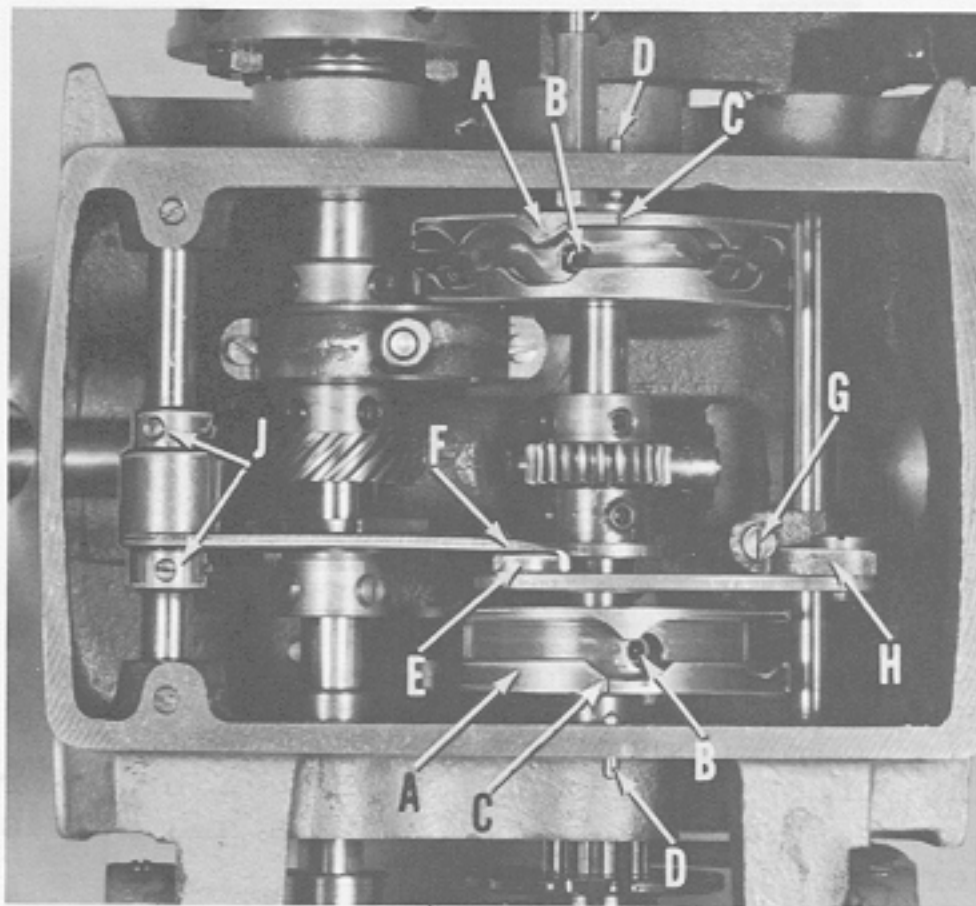

Fig. 4

rest against the needle bar clamp.

The needle bar is correctly positioned when the needle set screw (D) enters the slot in the needle bar bushing freely.

The position of the needle bar bushing is set to a gauge at the factory. The distance from its lower edge to the machined surface of the cylinder base is $3 \frac{1}{32}$ inches (Fig. 5).

ALIGNING FEED PLATE

Make sure that the feed plate (A, Fig. 6) is set so that it does not interfere with the needle at any point of its travel.

Adjustment is made by loosening two screws (B) and moving feed plate to desired position.

TIMING NEEDLE WITH HOOK

NOTE: Fig. 7 shows the machine with needle plate, feed plate and tacking clamp removed. This has been done for clarity only. These parts need not be removed to make the adjustments.

ADJUSTING NEEDLE BAR

When using short needles, use the upper pair of timing lines on the needle bar; for long needles, use the middle pair of timing lines; for extra long needles, use the lower pair.

Take machine out of stop position and turn pulley two complete revolutions in operating direction.

With the needle bar in its lowest position, the upper line of each pair of timing lines (A, Fig. 5), depending on which length of needle is used, should be even with the lower edge of the needle bar bushing.

To raise or lower needle bar, loosen needle bar clamp screw (B) and take-up clamp screw (C), move bar to desired height and retighten screws. The take-up clamp must

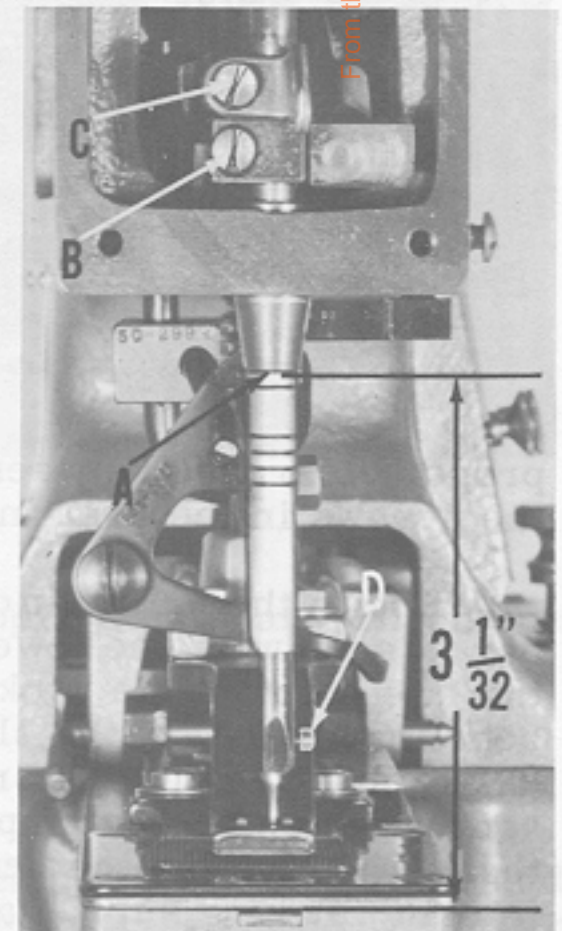

Fig. 5

(b) TIMING NEEDLE WITH HOOK (Continued)

Take machine out of stop position and rotate pulley two complete revolutions in operating direction. Lower the needle bar until it reaches its lowest position, then,

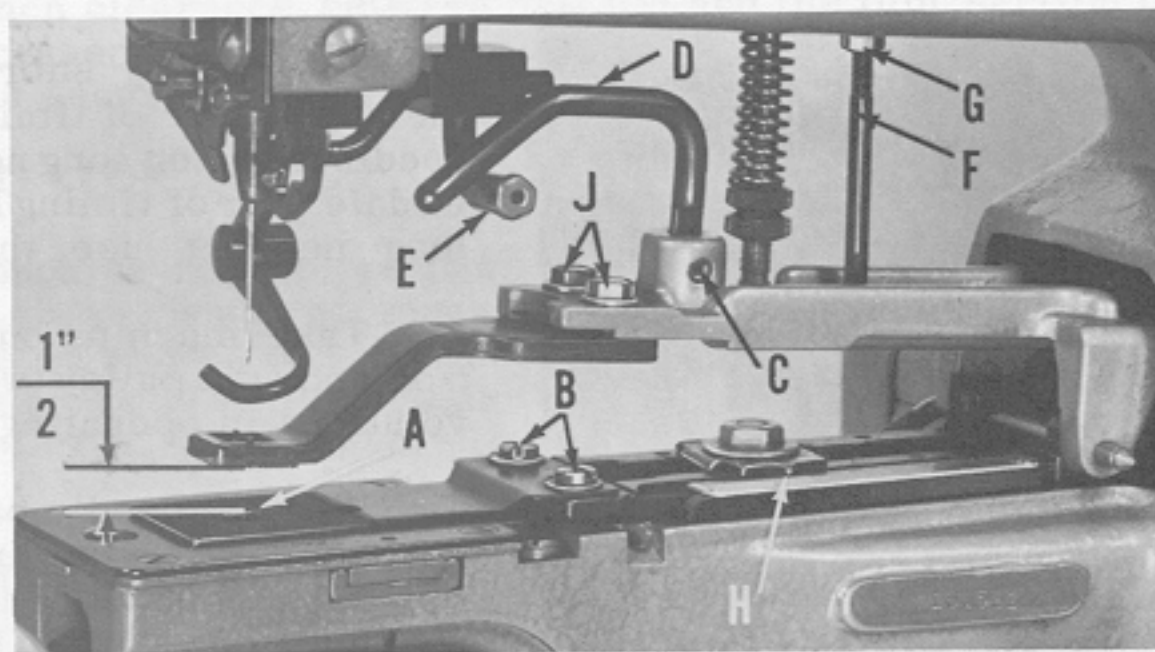

Fig. 6

raise it until the lower edge of the needle bar bushing is midway between the upper pair of timing lines on the bar when using short needles. (When the machine is equipped with long needles, use the lower pair of timing lines).

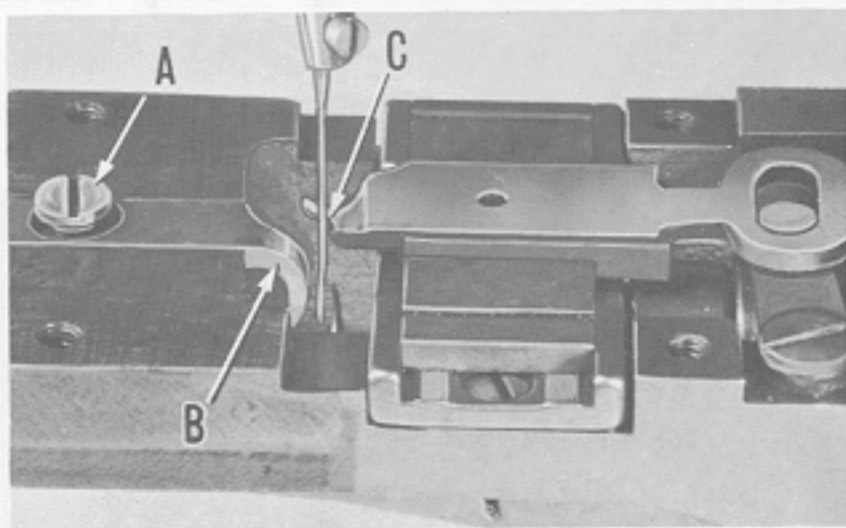

Fig. 7

Loosen needle guard clamp screw (A, Fig. 7) and slide needle guard (B) forward. Insert a screwdriver behind the loop positioning finger (C) and pull the finger forward. There should be only the slightest amount of clearance between the finger and needle, approximately .002 inch.

To make this adjustment, loosen set screws (A, Fig. 8) in the sleeve (B), slide sleeve forward slightly and retighten one of the screws enough to prevent the sleeve sliding on the shaft during adjustment. Now, loosen screws (C) in cam (D) and slide cam in the direction necessary to secure the proper clearance between the loop positioning finger and the needle. Tighten one of the screws in the cam and slide the sleeve back so that it contacts the cam.

Rotate the pulley in operating direction until the lower timing line on the needle bar is even with the lower edge of the needle bar bushing. Rotate the sleeve (B) so that the point of the hook is at the center of the needle on the back side and tighten both screws (A) in the sleeve. Loosen hook collar clamp screw (E) and slide hook (G) so that there is the smallest amount of clearance between its point and the needle and retighten hook clamp screw. Loosen set screw (C) in cam (D) and rotate cam so that its timing line coincides with the timing line on the sleeve (F). Tighten screws in cam, making sure that the cam is against the sleeve. Turn the pulley in operating direction until the needle bar is at its lowest position and slide the needle guard (B, Fig. 7) in the direction of the needle until there is a clearance of about .002 inch between it and the needle. Retighten clamp screw (A) securely.

HEIGHT OF TACKING CLAMP

With the machine in stop position, the normal distance between the bottom of the tacking clamp to the top of the feed plate should be 1/2 inch (Fig. 6). To make this adjustment, loosen set screw (C) and raise or lower rod (D).

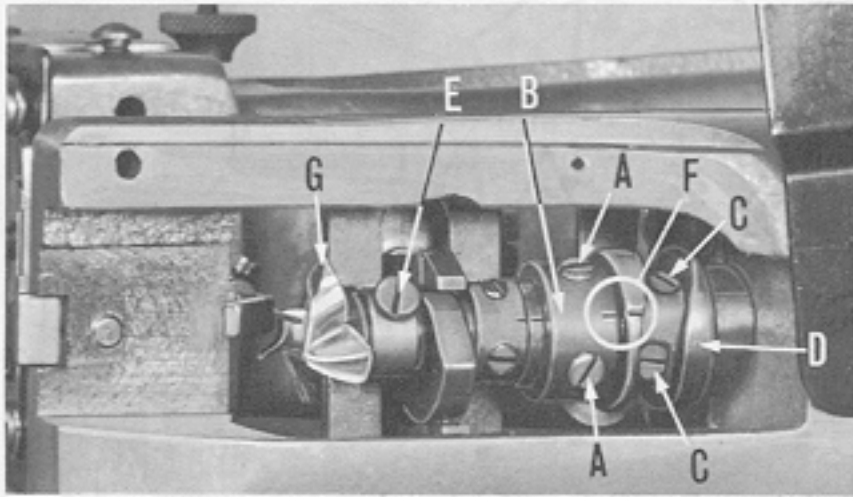

Fig. 8

Take machine out of stop position and turn pulley in operating direction until tacking clamp is in its furthest position to the rear. At this point, there must be clearance between the tacking clamp lifting rod (D, Fig. 6) and the tacking clamp lifting roller (E). Adjustment is made by loosening screw (C) and moving rod (D) up. This will affect the height of the tacking clamp in relation to the feed plate as previously described, but for the normal setting of 1/2 inch, no interference between lifting rod and roller will occur.

Return the machine to stop position and check the position of the tacking clamp stop pin (F, Fig. 6). Its purpose is to prevent overthrow of the tacking clamp so that the needle will not strike any part of the tacking clamp. Insufficient clearance between the stop pin and the tacking clamp holder will cause the machine to re-cycle. Height of stop pin (F) can be adjusted after loosening nut (G). When correct height has been obtained, tighten nut (G) against bed arm securely.

POSITIONING AND ADJUSTING TACKING CLAMP

Accurately measure the distance between the holes of the tack and set the pivot indicator (H, Fig. 6) and spring indicator (A, Fig. 9) to the graduations corresponding to the distance between the holes in the tack.

Take the machine out of stop position, turn slowly by hand and observe that the needle enters the tack and clears the cutting knife of the clamp. Equal distance should be maintained from the needle holes to the cutting knife when the needle enters in front of and behind the cutting knife. The tacking clamp may have to be shifted to obtain this condition. Loosen screws (J, Fig. 6) to make this adjustment. . . . retighten screws.

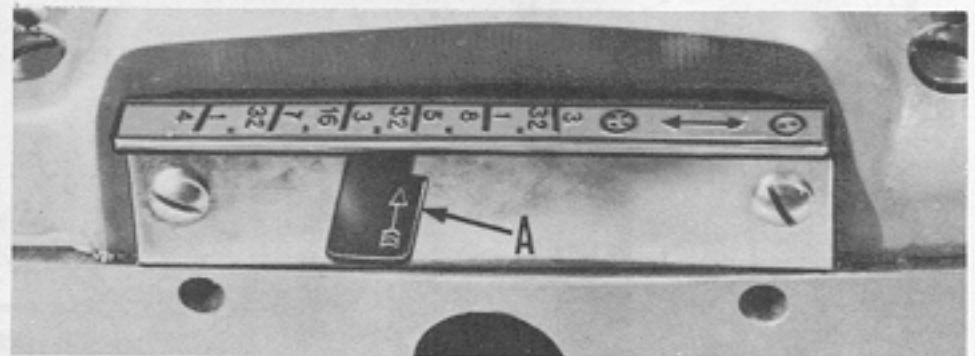

Fig. 9

The graduations on the indicator scales are only approximate and it may be necessary to deviate slightly from them.

THREAD TENSION

The regular thread tension (A, Fig. 10) is located behind the automatic thread tension (B) and controls the tightness of the tack. The tension required will vary in relation to the types of thread and thickness of materials and label used. Normally, only a light tension is required.

THREAD TENSION (Continued)

Take machine out of stop position, rotate pulley two complete turns in operating direction and thread machine in accordance with threading diagram (Fig. 11).

Check the position of the tension releasing lever (C, Fig. 10) to see that it comes as close as possible to the tension discs (D) without contacting them. Adjustment is made by loosening screw (E) and moving the lever (C) in the required direction.

AUTOMATIC THREAD TENSION

The automatic tension controls the tightness of the stitch on the underside of the fabric.

With the tension nut (A, Fig. 12) turned down about four or five turns, the automatic thread tension should release the thread when the needle bar, on its upstroke, has risen to a point where the lower edge of its bevelled top is $1 \frac{9}{16} + \frac{1}{32}$ inch above the top edge of the upper needle bar bushing as shown at dimension "X" (Fig. 12) on machines using short needles. When using long needles, the needle bar must be allowed to rise until dimension "X" is $1 \frac{15}{16} + \frac{1}{32}$ inch. For extra long needles, this dimension should be $2 \frac{1}{8} + \frac{1}{32}$ inch.

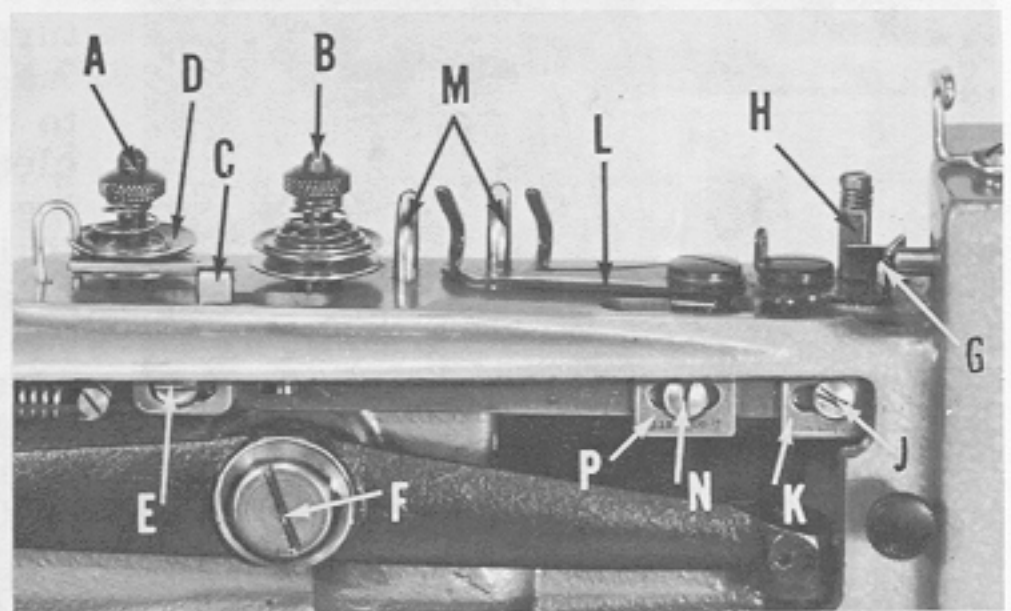

Fig. 10

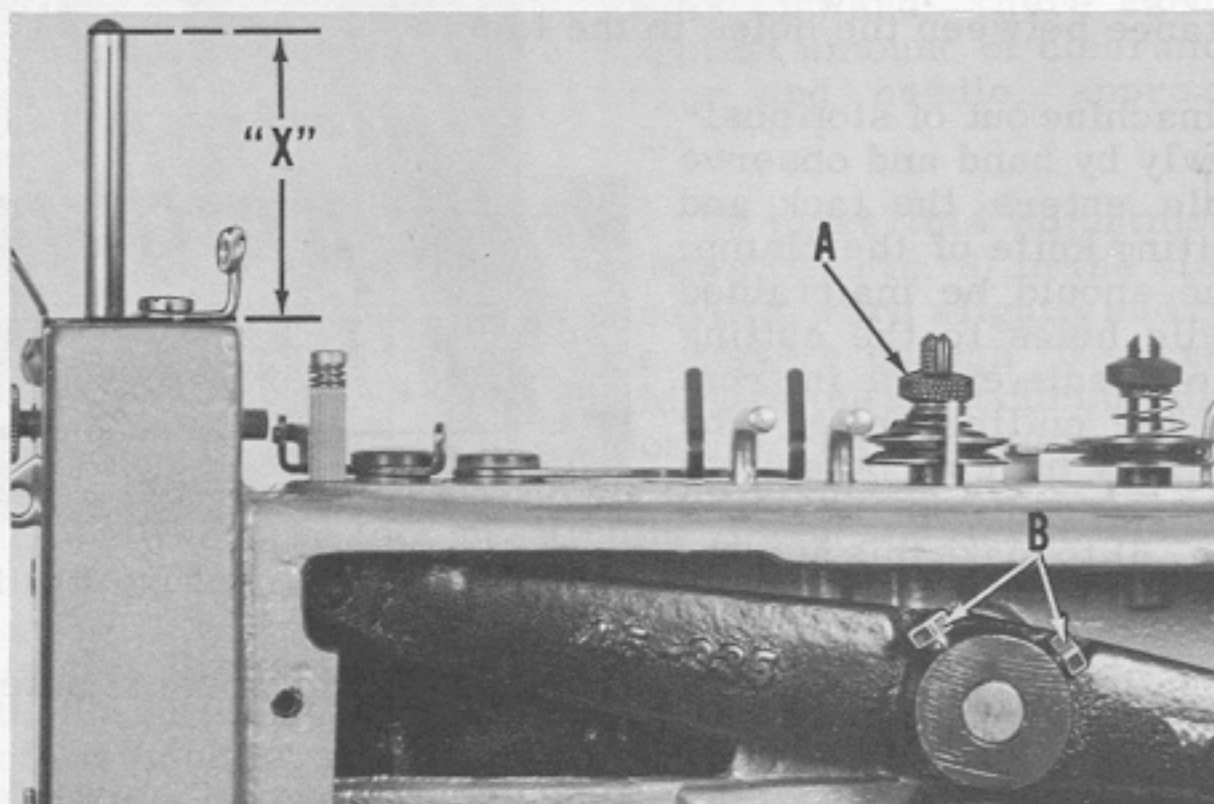

Fig. 12

To make this adjustment, turn pulley in operating direction until the needle bar has risen to the heights described above. Loosen the two hexagonal head screws (B, Fig. 12) in needle lever hub and turn needle lever shaft (F, Fig. 10) with a screwdriver until the tension releases.

**THREADING AND OILING
DIAGRAM FOR
LEWIS CLASS 200**

OIL GEARS

**REMOVE COVER AND OIL
ALL WORKING PARTS**

OIL NEEDLE BAR

GREASE HERE

Fig. 11

From the library of: Diamond Needle Co.

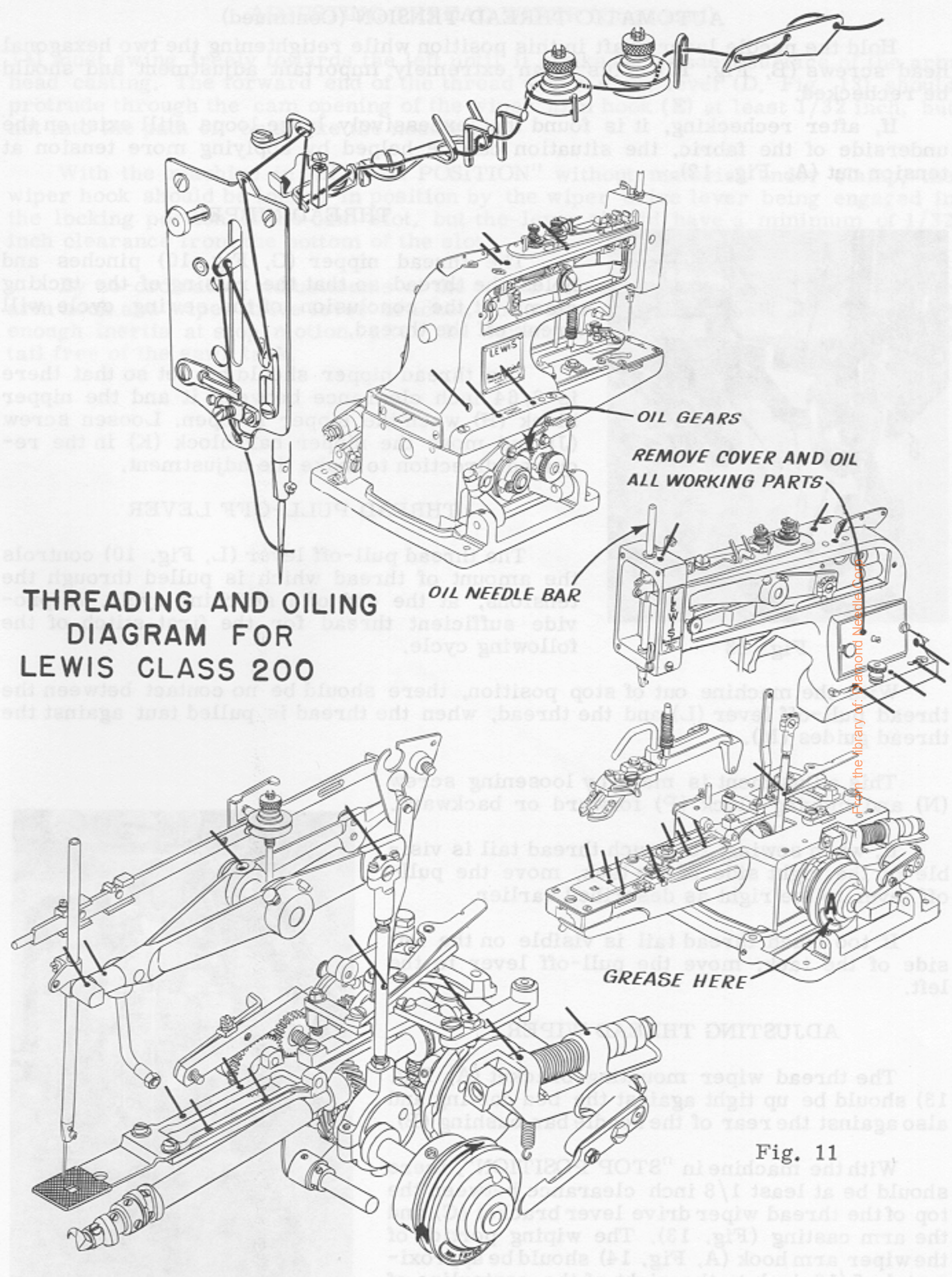

AUTOMATIC THREAD TENSION (Continued)

Hold the needle lever shaft in this position while retightening the two hexagonal head screws (B, Fig. 12). This is an extremely important adjustment and should be rechecked.

If, after rechecking, it is found that excessively large loops still exist on the underside of the fabric, the situation can be helped by applying more tension at tension nut (A, Fig. 12).

THREAD NIPPER

The thread nipper (G, Fig. 10) pinches and holds the thread so that the raising of the tacking clamp at the conclusion of the sewing cycle will break off the thread.

The thread nipper should be set so that there is $\frac{3}{64}$ inch clearance between it and the nipper block (H) when the nipper is open. Loosen screw (J) and move the nipper bar block (K) in the required direction to make the adjustment.

THREAD PULL-OFF LEVER

The thread pull-off lever (L, Fig. 10) controls the amount of thread which is pulled through the tensions, at the end of a stitching cycle, to provide sufficient thread for the first stitch of the following cycle.

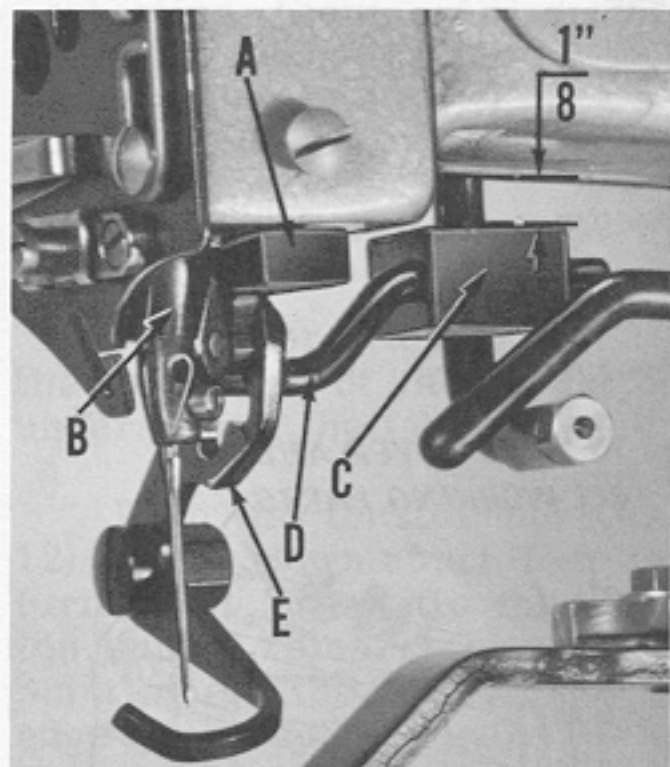

Fig. 13

With the machine out of stop position, there should be no contact between the thread pull-off lever (L) and the thread, when the thread is pulled taut against the thread guides (M).

This adjustment is made by loosening screw (N) and moving block (P) forward or backward.

If, when sewing, too much thread tail is visible on the right side of the tack, move the pull-off lever to the right as described earlier.

If too much thread tail is visible on the left side of the tack, move the pull-off lever to the left.

ADJUSTING THREAD WIPER

The thread wiper mounting bracket (A, Fig. 13) should be up tight against the bed casting and also against the rear of the needle bar bushing (B).

With the machine in "STOP POSITION", there should be at least $\frac{1}{8}$ inch clearance between the top of the thread wiper drive lever bracket (C) and the arm casting (Fig. 13). The wiping portion of the wiper arm hook (A, Fig. 14) should be approximately $\frac{5}{16}$ inch to the right of the centerline of the needle (Fig. 14). The wiper arm hook (A, Fig.

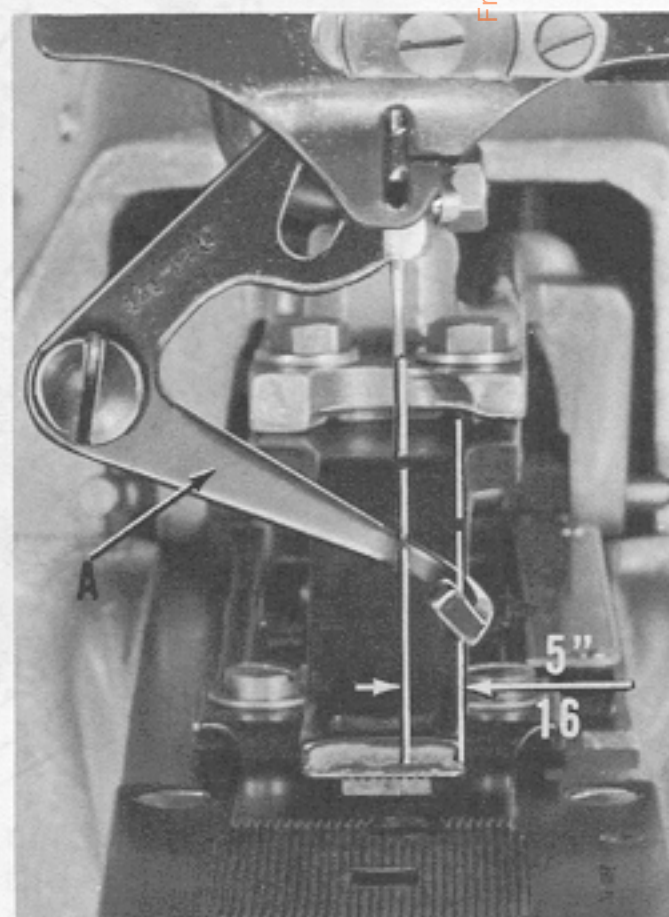

Fig. 14